

UV300 MICROVERTER® SERIES

126-252 WATTS 300VDC INPUT 3/4 BRICK SINGLES FULL BRICK TRIPLES

DESCRIPTION

The μ V300 Series are high density DC-DC converters designed for use in telecom and other centralized modular and distributed power applications. The μ V300 Series use metal PC boards, planar transformers, and surface mount construction to produce up to 252 watts in a tiny package.

FEATURES

- Miniature Size
- High Density – Up to 58 W/in.3
- Constant Frequency – 370KHZ
- Parallelable with Current Sharing
- Fault Tolerant – n+m Redundancy
- Extremely Low Thermal Resistance
- Output Good Signal
- Optional Sync Pin
- Non-Shutdown OVP
- Logic On-Off
- Thermal Protection
- Current Limit/Short Circuit Protection
- UL/CSA/TUV/CE MARK Approvals

MODEL SELECTION

Model	Output Voltage	Output Current
μ V300-2	2.1V	60A
μ V300-3	3.3V	50A
μ V300-5	5V	40A
μ V300-8	8V	30A
μ V300-12	12V	20A
μ V300-15	15V	16A
μ V300-24	24V	10A
μ V300-28	28V	9A
<hr/>		
μ V300-T512	5V	35A*
	12V	3A*
	-12V	3A*
<hr/>		
μ V300-T515	5V	35A*
	15V	3A*
	-15V	3A*

*Maximum Total Output Power 185 W.

Option:- A Output Good Deleted
 - S Sync. Pin Option



SINGLE OUTPUT

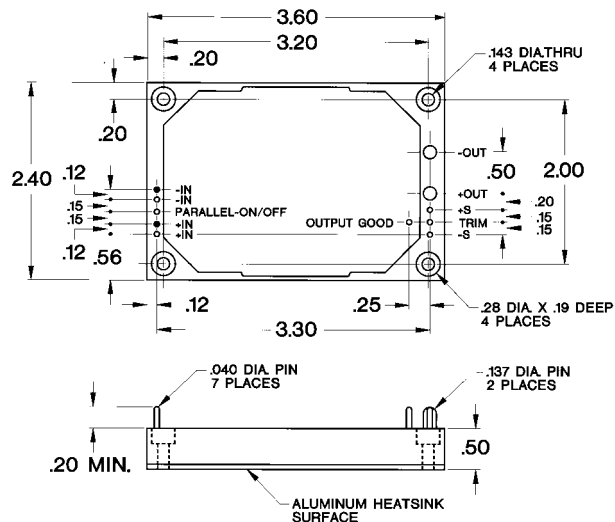

TRIPLE OUTPUT

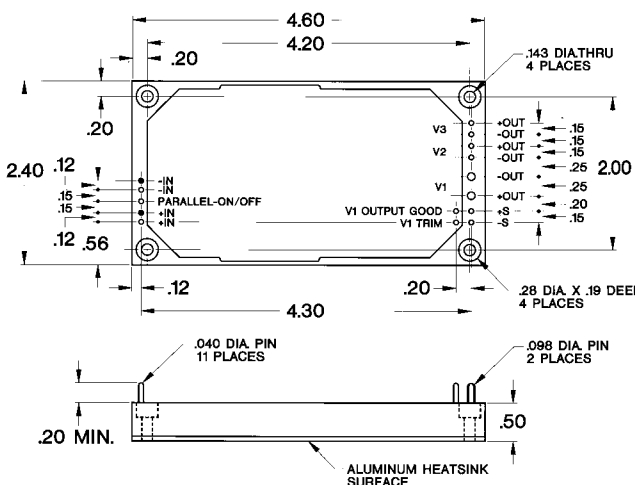

Note: Filled Pins (marked •) are not provided in μ V300 series models

UV300 MICROVERTER SERIES SPECIFICATIONS

		Min	Typical	Max	Units	Conditions	
INPUT	Input voltage	220	300	400	VDC		
	Brownout	180			VDC	75% full output	
	In rush charge		4.5x10 ⁻⁵		Coulombs		
	Input reflected ripple		20		%	full load, nominal line	
	No load power dissipation		2.5		watts	singles	
			7.5		watts	triples	
	Logic disabled power in Input ripple rejection		1 60		watts dB	 @ 120 Hz	
OUTPUT	(Singles and Main Output of Triple)						
	Set point accuracy			±1	%	no load	
	Load regulation		.02	.2	%	0 to full load	
	Line regulation		.02	.2	%	over range	
	Ripple		1	3	%p-p	0 to 20MHz	
	Trim range	±10			%	consult factory for extended range	
	Remote sense compensation			0.5	V total		
	OVP (non shutdown auto. recovery)		120*		%	* or Vout +.5V whichever is greater	
	Current Limit (auto.recovery)		110-120		%	full load	
	Current sharing (automatic)		±5		%	full load	
	Transient response singles		50		µs	20-80% load, .5A/µs, Vout 1%	
	Transient response main output triples	200			µs	10-20A, aux. loads 2.5A, .25A/µs, Vout 1%	
	Transient response		<i>See web site: www.roassoc.com</i>				
	Temp drift			.02	%/°C		
	Efficiency		<i>See Curves on Page 80</i>				
OUTPUT	(Auxiliary Outputs of Triples)						
	Set point accuracy		±0.5	±1	%	10A on main, no load auxiliaries	
	Load regulation		.2	.5	%	0 to full load	
	Line regulation		.01	.1	%	over range	
	Ripple		.25	.5	%p-p	0 to 20 mHz	
	Current Limit (auto.recovery)		110-120		%	full load	
	Transient response		200		µs	20-80% load, Vout within 1%	
	Transient response		200		µs	low line to high line, Vout 1%	
	Transient response		200		µs	50-100% load, Vout 1%	
Temp drift			.06	%/°C			
CONTROL	Turn on time		250		ms	input power applied, Vout 1%	
	Logic turn on time		2		ms	Vout within 1%	
	Logic disabled current		1		mA	sink	
ISOLATION	Input to output	4500			VDC	consult factory for procedure	
	Input to case	2500			VDC		
	Output to case	500			VDC		
	Input to output capacity		5700		pF		
THERMAL	Operating temperature	-40		+100	°C case		
	Automatic shut down temperature	+100	+105	+110	°C case		
	Thermal resistance case to ambient		4.2		°C/w	single @ Tc=100°C	
			3.3		°C/w	triple @ Tc=100°C	
WEIGHT	singles		7		oz.		
	triples		9		oz.		
SIZE	singles		0.5x2.4x3.6		inches		
	triples		0.5x2.4x4.6		inches		

EFFICIENCY CURVES

CONTINUED

MICROVERTER SERIES

2, 3 and 5V Output Models

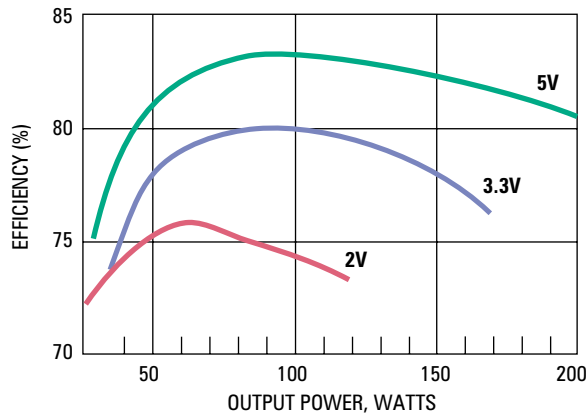

12 and 24V Output Models

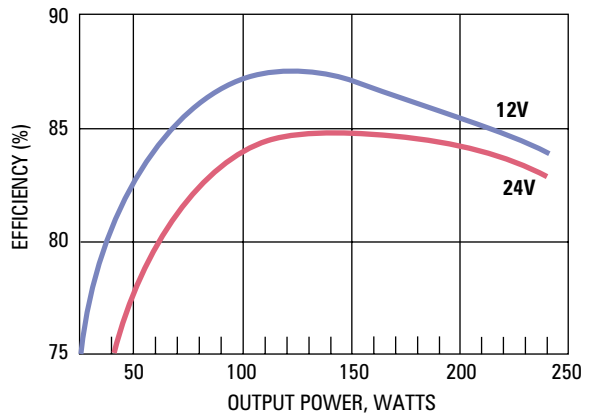

Triple Output Models

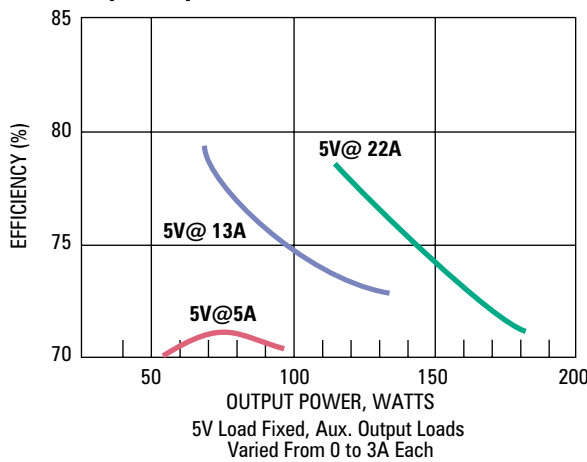

Triple Output Models

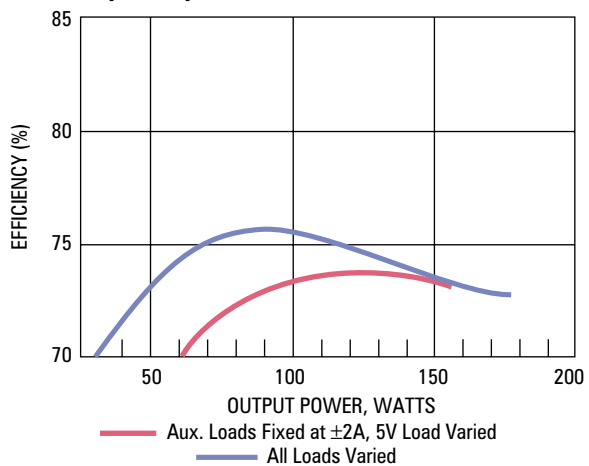

MINIMUM LOAD-TRIPLES

Minimum 5V Load vs. Auxiliary Output Power
μV28 and μV48-Triple Output Models

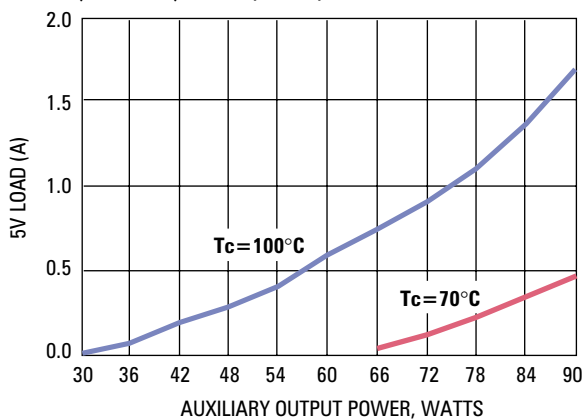

Minimum 5V Load vs. Auxiliary Output Power
μV300 Triple Output Models

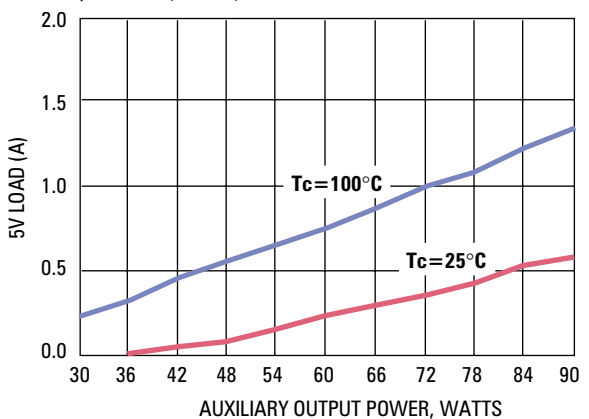

Note: Efficiencies are typical for Tc=25°C and Nominal Input. Input and Output Voltages are measured at the Pins.