

UV28 MICROVERTER® SERIES

126-252 WATTS 28VDC INPUT 3/4 BRICK SINGLES FULL BRICK TRIPLES

DESCRIPTION

The μ V28 Series are high density DC-DC converters designed for use in telecom and other centralized modular and distributed power applications. The μ V28 Series use metal PC boards, planar transformers, and surface mount construction to produce up to 252 watts in a tiny package.

FEATURES

- Miniature Size
- High Density – Up to 58 W/in.3
- Constant Frequency – 370KHZ
- Parallelable with Current Sharing
- Fault Tolerant – n+m Redundancy
- Extremely Low Thermal Resistance
- Output Good Signal
- Optional Sync Pin
- Non-Shutdown OVP
- Logic On-Off
- Thermal Protection
- Current Limit/Short Circuit Protection

MODEL SELECTION

Model	Output Voltage	Output Current
μ V28-2	2.1V	60A
μ V28-3	3.3V	50A
μ V28-5	5V	40A
μ V28-8	8V	30A
μ V28-12	12V	20A
μ V28-15	15V	16A
μ V28-24	24V	10A
μ V28-28	28V	9A
μ V28-T512	5V	35A*
	12V	3A*
	-12V	3A*
μ V28-T515	5V	35A*
	15V	3A*
	-15V	3A*

*Maximum Total Output Power 185 W.
 Option:- A Output Good Deleted
 - S Sync. Pin Option



SINGLE OUTPUT

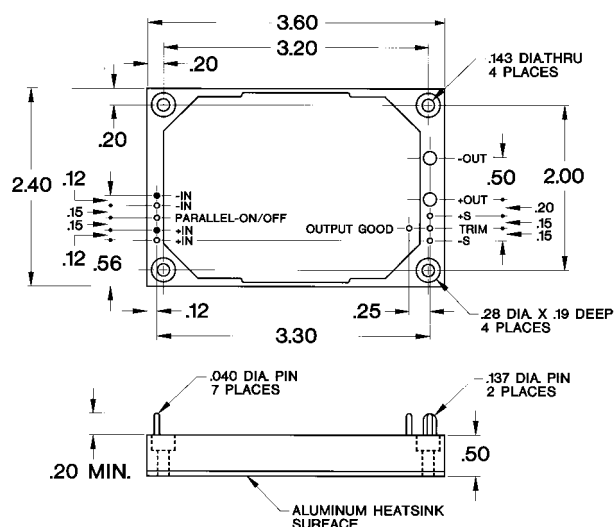

TRIPLE OUTPUT

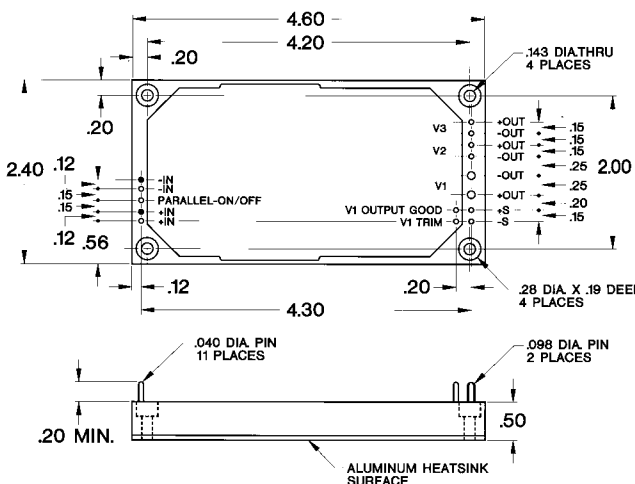

UV28 MICROVERTER SERIES SPECIFICATIONS

		Min	Typical	Max	Units	Conditions
INPUT	Input voltage	20	28	32	VDC	
	Brownout	18			VDC	75% full output
	In rush charge		2.6x10 ⁻⁴		Coulombs	
	Input reflected ripple		20		%	Full Load, nominal line
	No load power dissipation		1.5		watts	singles
			7.5		watts	triples
	Logic disabled power in		.35		watts	
	Input ripple rejection		60		dB	@ 120 Hz
	Input overvoltage	32		60	VDC	no damage to units
OUTPUT	(Singles and Main Output of Triple)					
	Set point accuracy			±1	%	no load
	Load regulation		.02	.2	%	0 to Full Load
	Line regulation		.02	.2	%	over range
	Ripple		1	3	%p-p	0 to 20MHz
	Trim range	±10			%	consult factory for extended range
	Remote sense compensation			0.5	V total	
	OVP (non shutdown auto. recovery)		120*		%	* or Vout +.5V whichever is greater
	Current Limit (auto.recovery)		110-120		%	Full Load
	Current sharing (automatic)		±5		%	Full ILoad
	Transient response singles		50		μs	20-80% load, .5A/μs, Vout 1%
	Transient response main output triples	200			μs	10-20A, aux. loads 2.5A, .25A/μs, Vout 1%
	Transient response	<i>See web site: www.roassoc.com</i>				
	Temp drift			.02	%/°C	
Efficiency	<i>See Curves on Page 80</i>					
OUTPUT	(Auxiliary Outputs of Triples)					
	Set point accuracy		±0.5	±1	%	10A on main, no load auxiliaries
	Load regulation		.2	.5	%	0 to full load
	Line regulation		.01	.1	%	over range
	Ripple		.25	.5	%p-p	0 to 20 mHz
	Current Limit (auto.recovery)		110-120		%	Full Load
	Transient response		200		μs	20-80% load, Vout within 1%
	Transient response		200		μs	low line to high line, Vout 1%
	Transient response		200		μs	50-100% load, Vout 1%
Temp drift		.06		%/°C		
CONTROL	Turn on time		2.5		ms	input power applied, Vout 1%
	Logic turn on time		1		ms	Vout within 1%
	Logic disabled current		1		mA	sink
ISOLATION	Input to output	1000			VDC	consult factory for procedure
	Input to case	1000			VDC	
	Output to case	200			VDC	
	Input to output capacity		2200		pF	
THERMAL	Operating temperature	-40		+100	°C case	
	Automatic shut down temperature	+100	+105	+110	°C case	
	Thermal resistance case to ambient		4.2		°C/w	single @ Tc=100°C
			3.3		°C/w	triple @ Tc=100°C
WEIGHT	singles		7		oz.	
	triples		9		oz.	
SIZE	singles		0.5x2.4x3.6		inches	
	triples		0.5x2.4x4.6		inches	

EFFICIENCY CURVES

CONTINUED

MICROVERTER SERIES

2, 3 and 5V Output Models

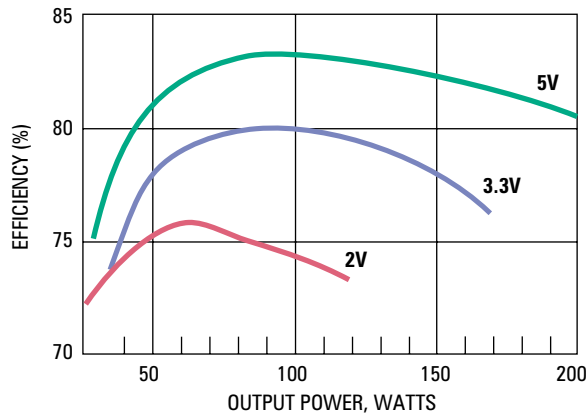

12 and 24V Output Models

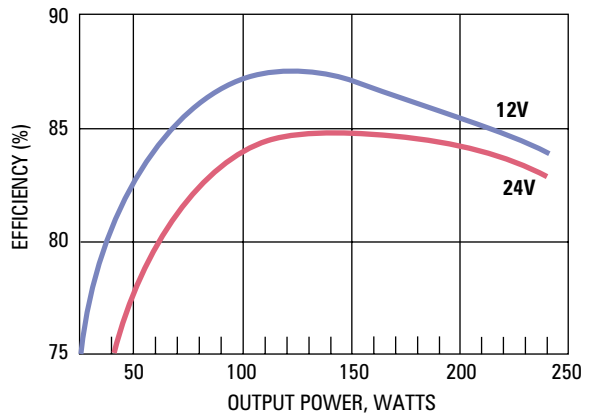

Triple Output Models

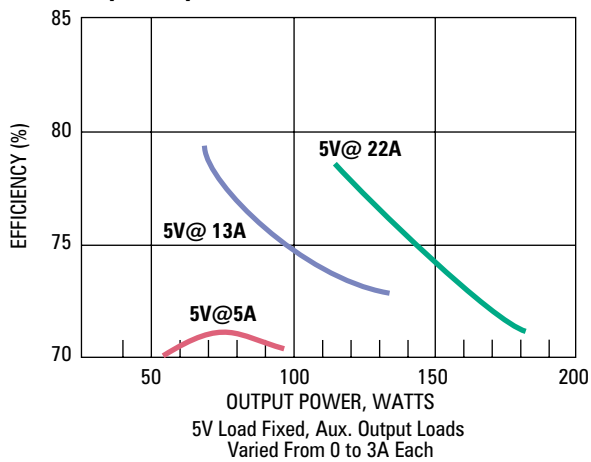

Triple Output Models

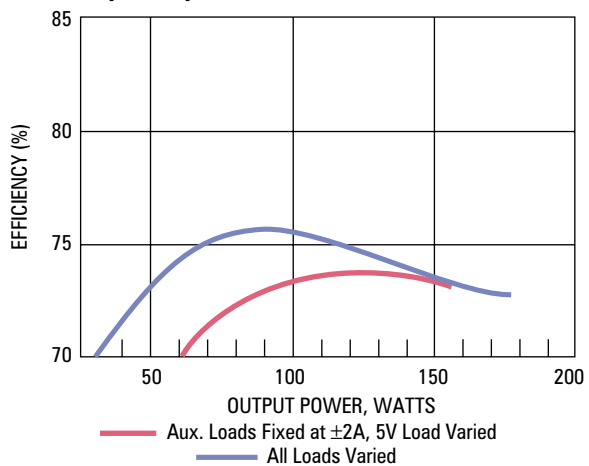

MINIMUM LOAD-TRIPLES

Minimum 5V Load vs. Auxiliary Output Power

μV28 and μV48-Triple Output Models

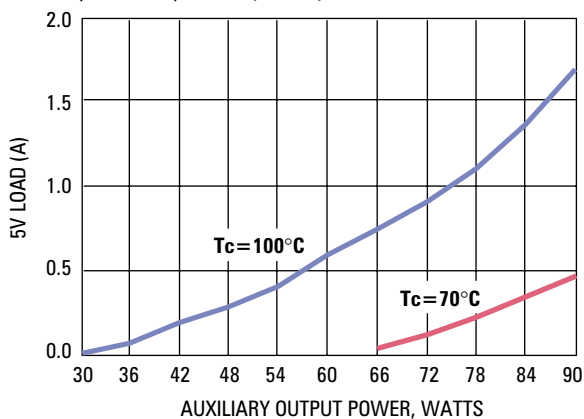

Minimum 5V Load vs. Auxiliary Output Power

μV300 Triple Output Models

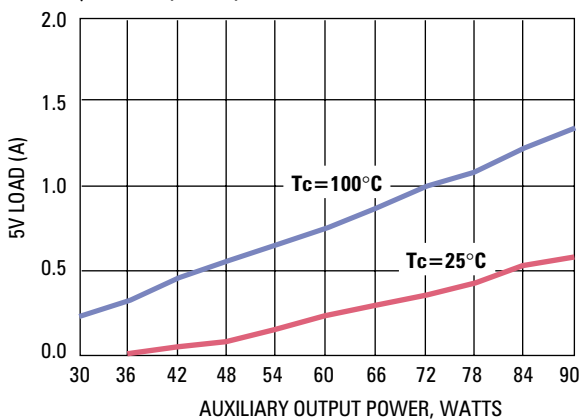

Note: Efficiencies are typical for Tc=25°C and Nominal Input. Input and Output Voltages are measured at the Pins.