



9608/ 9608LF THERMAL PAD PRODUCT DATA SHEET

The 9608 and 9608LF* thermal pads are designed for nanoVerter®, and picoVerter® modules. This high performance thermal pad has thermal conductivity similar to thermal grease but without the mess. A thermal pad is used between a module's baseplate and an attached heat sink to minimize the thermal impedance between them.

These thermal pads are made from a foil-like material called GRAFOIL†. GRAFOIL is a soft, flexible material used for gaskets and as a thermal interface. It is made mostly from graphite powder formed into thin sheets. The graphite in the pad fills holes, pits, and indentations in the two mating surfaces; reducing the amount of air (an insulator) between them. See Application Note 10 Thermal Considerations, or the application note for the module you are using to get further information on how to select thermal pads.

Physical Properties	Value	Units	Test Method
Thickness	0.005	in	ASTM D1000
Color	Dark Gray		Visual
Filler Material	Graphite		
Density	1.12	g/cc	ASTM F-1315
Compressibility	43	%	ASTM F-36
Recovery	15	%	ASTM F-36
Creep Relaxation	< 5	%	ASTM F-38
Tensile Strength (along length & width)	650	psi	ASTM F-152
Compressive Strength (thru thickness)	35000	psi	ASTM C-695
Modulus of Elasticity	0.2×10^{-6}	psi	
Young's Compressive Modulus (thru thickness)	27000	psi	
Temperature Range	-240 to 450	°C	
Thermal Conductivity (along length & width)	140	W/m-K	
Thermal Conductivity (thru thickness)	5	W/m-K	
Thermal Expansion (thru thickness)	27	$\mu\text{m}/\text{m}^\circ\text{C}$	
Leachable Chloride Content	< 50	ppm	
Sulfur Content	550	ppm	
Specific Heat	711	J/kg*K	

MECHANICAL DIMENSIONS

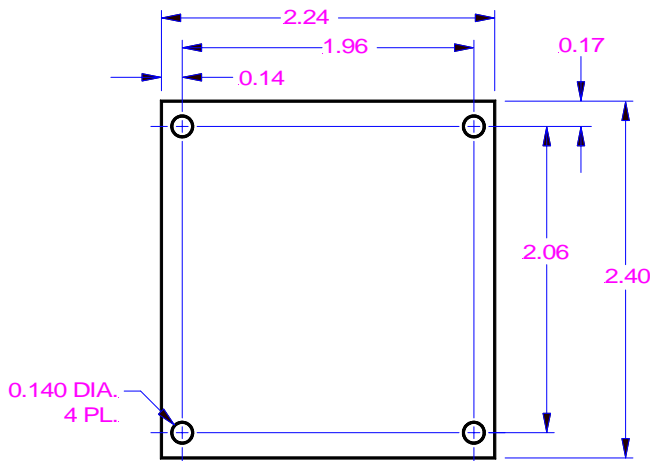

* The 9608 and 9608LF part numbers both refer to the same physical product. This product is, and has always been, lead free and fully compliant with the European RoHS directive.

† The GRAFOIL material was originally developed by Union Carbide. GRAFOIL is a registered trademark of Union Carbide.



Lead Free



RoHS Compliant

RO Associates, Inc.
894 Faulstich Ct.
San Jose, CA 95112

www.roassoc.com
rev 070921
email:sales@roassoc.com

800-443-1450
408 200-3040
fax: 408 200-3061